

IRBS3-CP

COMMERCIAL Tap Range Infrared Automatic Timed Flow Basin Spout Chrome



Features:

- Non-touch control, using Infrared sensing technology
- Supports infection control measure
- Automatic switch off supports water saving
- BREEAM compliant
- Mains or battery powered options
- This tap outputs a fixed water temperature and should only be installed in conjunction with an approved thermostatic mixing valve to meet Part-G of the building regulations.

Product Certifications:



WRAS Cert. Number: 2309368
WRAS Expiry Date: 30/09/2028



For more products, visit our website:
<http://www.bristan.com>



Specification

Product Type:	Commercial Tap
Main Construction Material:	Brass
Mount Type:	Deck Mounted
Connection Inlet:	G $\frac{1}{2}$ "
Connection Outlet:	5ltr/min flow straightener
Number of Tap Holes:	1
Valve/Cartridge Type:	Solenoid Valve
Plumbing System Requirements:	Suitable for high pressure systems
Minimum Dynamic Pressure (bar):	1.0 bar
Maximum Dynamic Pressure (bar):	5.0 bar
Maximum Hot Water Temperature °C:	65
Maximum Static Pressure (bar):	10
Flow Type:	Single Flow
Isolation Included:	No

Dimensions (measurements in mm)

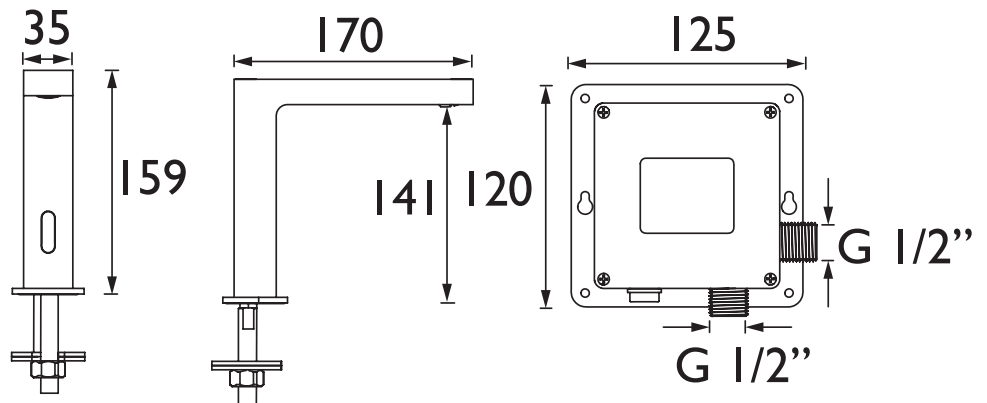

Flow Rates (l/min)

System Pressure (bar)	1	2	3	5
IRBS3-CP	3.6	4.6	4.7	4.9

TECHNICAL
DATA
SHEET



BRISTAN